



Engineered for Vehicles. Designed for Life.

Lund International has been engineering and manufacturing innovative, high quality truck and automotive accessories since 1974. For more than 30 years, light truck enthusiasts have chosen Lund brand products because they demand the best for their vehicle. From running boards to tonneaus, tool boxes to grilles, hood shields to cargo management, Lund brand products offer a unique blend of form and function that provides outstanding value. Put simply, Lund brand accessories are engineered to work, designed to last and crafted to look great.

At Lund International, we constantly strive to improve and enhance our line of automotive accessories. The products and specifications included in our 2008 catalog are subject to change without notice. If you have questions, please contact Lund International customer service.



Lund Automotive Accessories Catalog 2008 **TABLE OF CONTENTS**

GRILLES	PAGES 4-13	RUNNING BOARDS (CONTINUED)	PAGES
Grille Program	4-5	Trailback™	
3D Flame Grille	6	Delta III™	
Edge-Cut Grille	7	Challenger™	
Diamond Plate Grille	8	SuperStep™	
Elliptical Grille	9	Runners™	
Framed Perimeter Grille	10	Sidetracker™	
Original Bar Grille	11	X-Step™	
Stainless Mesh Grille	12	CARGO MANAGEMENT	PAGES
Billet Accessories	13	HitchRack™ Truck Bed Extender	
HOODSHIELDS	PAGES 14-19	Drop Down Bike Carrier	
Stainless Interceptor	16	Dual Bike Carrier	
Interceptor II	17	Roof Top Cargo Rack	
Interceptor	18	Roof Top Cargo Netting	
Avenger	19	Aero Bag Waterproof Roof Top Carrier	
HOODSCOOPS	PAGES 20-21	Soft Pack Roof Top Bag	
Hoodscoops	20-21	Hitch-Mounted Cargo Carriers	
VISORS	PAGES 20-21	Do It Yourself Cargo Carrier Kit	
SunVisor		Cargo Carrier Accessories	
SunVisor II		Cargo Bars	
Moonvisor		Hitchstep™	
Solar Visor		Folding Aluminum Ramp	
Lunar Visor		Folding Aluminum Arched Ramp	
WINDOW VENTS AND ACCESSORIES	PAGES	Bi-Fold Ladder Ramp	
Window Vents		Tri-Fold Ladder Ramp	
In-Channel Window Vents		Ramp Kit	
Side Window Cover		Cargo•Logic®	
AIR DEFLECTORS / CAB FAIRING	PAGES	Cargo•Loks	
Racerback		Cargo Logic Tote	
Fastback		FLOOR PROTECTION	PAGES
WindJammer		Catch-All Premium Floor Protection	
Shadow		Xtreme Catch-All Floor Protection	
TONNEAUS / BED ACCESSORIES	PAGE	STORAGE BOXES	PAGES
Genesis™ Roll Up		Seal-Tite™ Series	
Genesis™ Tri-Fold		Seal-Tite™ Low Profile	
Genesis™ Snap		Challenger™ Series	
Genesis™ Seal & Peel		Challenger™ Low Profile	
Genesis™ Hinged		Challenger™ Specialty Series	
Genesis™ Tailgate Seal		Ultima™ Series	
RUNNING BOARDS	PAGES	Contender™ Series	
Multi-Fit Running Board Program		Tool Box Accessories	
OE Style No Drill Bracket / EZ Bracket		MUD FLAPS	PAGES
Tube Step		Mud Flaps	
Factory Style		Warranty	
Rugged™ Series			
Steprails™			
Trailrunner™			



First Impressions are Everything

LEAD WITH THE BEST...

Your vehicle's grille makes a statement. With a Lund grille, you're telling the world that you settle for nothing less than the best. Cookie cutter grille covers are not going to cut it on your ride. With seven unique styles – four of which are Lund exclusives – you'll find a Lund grille that fits not only your vehicle, but your lifestyle.

The Finest Materials

Lund Grilles are built to last. We begin with the best materials. Lund billet grilles are crafted from high-grade aluminum. Our mesh grilles feature 12-gauge, 304 high-grade stainless steel. The unique Lund Diamond Plate grilles are made of tough, 3/16 inch aluminum.

LUND GRILLES



3D Flame Grille



Diamond Plate



Original Bar



Framed Perimeter



Stainless Steel Mesh



Elliptical



Edge-Cut

Lund Exclusives

Lund Classics

More Bars

Lund Original Bar, Edge-Cut and Framed Perimeter Grilles have more bars than most competitors. And, because of our advanced laser and water jet manufacturing processes, the bars are evenly spaced. This adds to both the look and strength of the grille.

Superior Fit

Lund grilles are designed to closely fit the contours of each specific application. In addition, our grilles are known for their seamless look, hiding all weld points. Mounting hardware is the best, ensuring great looks for years to come. Many of our grilles have installation tabs integrated into the bar support. This reduces the number of welds, adding strength and simplifying installation.

Make the best possible impression with the best possible grille. Get the look with Lund!



Lund
Exclusive!

3D Flame Grille

One and Only



Patent pending 3D Flame design enhances the front end of today's popular vehicles



Cutting-edge laser technology ensures precision quality



Polished finish for the ultimate shine

- The only 3D flame grille available
- Far superior to "cookie cutter" flame grilles
- Polished finish for the ultimate shine
- Application specific designs for a custom fit and hassle-free installation
- Cutting-edge laser technology makes this grille unique

Styling Tip:

Looks great with:
Smoke HOOD SHIELD (page)
Smoke WINDOW VENTS (page ...)



Lund
Exclusive!

Innovative and Tough

Edge-Cut Grille

- Patent pending edge-cut design combines classic billet grille appearance with unique precision cuts for an eye-catching, one-of-a-kind look
- Premium grade billet aluminum ensures maximum durability
- Polished finish for maximum shine



Innovative edge-cut design for a one-of-a-kind look



Polished finish for the ultimate shine



Cutting-edge laser technology ensures precision quality

Styling Tip:

Get the Look with our
FASTBACK™ CAB FAIRING (page)



Diamond Plate Grille

Rugged and Eye-Catching



The perfect complement to other diamond plate accessories



Constructed from 3/16 inch diamond plate aluminum



Application specific designs for a custom fit

- Complements other diamond plate accessories
- Patent pending design provides a unique, rugged look
- 3/16 inch thick diamond plate aluminum for long-lasting strength

Styling Tip:

Looks great with diamond plate accessories:
STORAGE BOXES (pages)
MUD FLAPS (pages....)



Stylish and Unique

- Patented elliptical design provides a stylish, unique look
- Premium grade billet aluminum provides maximum durability
- Highly polished finish for the ultimate shine
- Cutting-edge laser technology ensures precision quality

Styling Tip:

Protect your bed and save gas with a
LUND TONNEAU COVER (pages)

Elliptical Grille



Patented elliptical design provides a stylish, unique look



Cutting-edge laser technology ensures precision quality

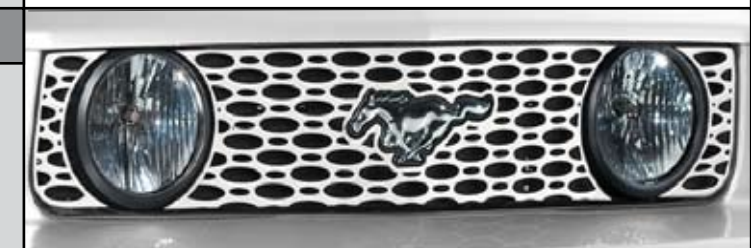

Polished finish for the ultimate shine



Framed Perimeter Grille

Clean and Sharp



All the qualities of an Original Bar grille with a framed appearance



Polished finish for the ultimate shine



Cutting-edge laser technology ensures precision quality

- Classic bar design with framed perimeter for a clean, crisp look
- Premium grade billet aluminum for maximum durability
- Highly polished finish for the ultimate shine

Styling Tip:

Keep the Chrome Coming:
AVS CHROME HOOD SHIELD
AVS CHROME VENT VISORS



Classic and Distinct

Original Bar Grille

- Made from premium grade billet aluminum for maximum durability
- More bars than competitive grilles for enhanced looks and strength
- Polished finish for the ultimate shine
- Cutting-edge laser technology ensures precision quality



Original bar design provides a classic, distinct look



Polished finish for the ultimate shine



Cutting-edge laser technology ensures precision quality

Styling Tip:

Don't forget a HOOD SHIELD.
Smoke or Clear Paint-to-Match (pages)



Stainless Steel Mesh Grille

Elegant and Stylish



Unique mesh design provides optimum style



Cutting-edge laser technology ensures precision quality



Polished finish for the ultimate shine

- Elegant and stylish design made more beautiful and durable by Lund
- Manufactured from tough and durable 12-gauge 304 high-grade stainless steel
- Each grille model is designed precisely for a specific application
- Laser technology ensures quality

Styling Tip:

A perfect match with a:
SMOKE HOOD SHIELD (pages)
SMOKE WINDOW VENTS (page...)

Billet Antenna



5.5 inch



9 inch



14 inch

Here's proof that a small change can make a big difference. Replace your stock antenna with a Lund Billet Antenna to signify your attention to detail, quality and style. It doesn't scream class, it simply states it.

- Durable one-piece design with polished finish for the ultimate shine
- CNC machined from solid aluminum for precision quality
- Adapters included for a hassle-free installation
- Available in 5.5 inch, 9 inch and 14 inch lengths



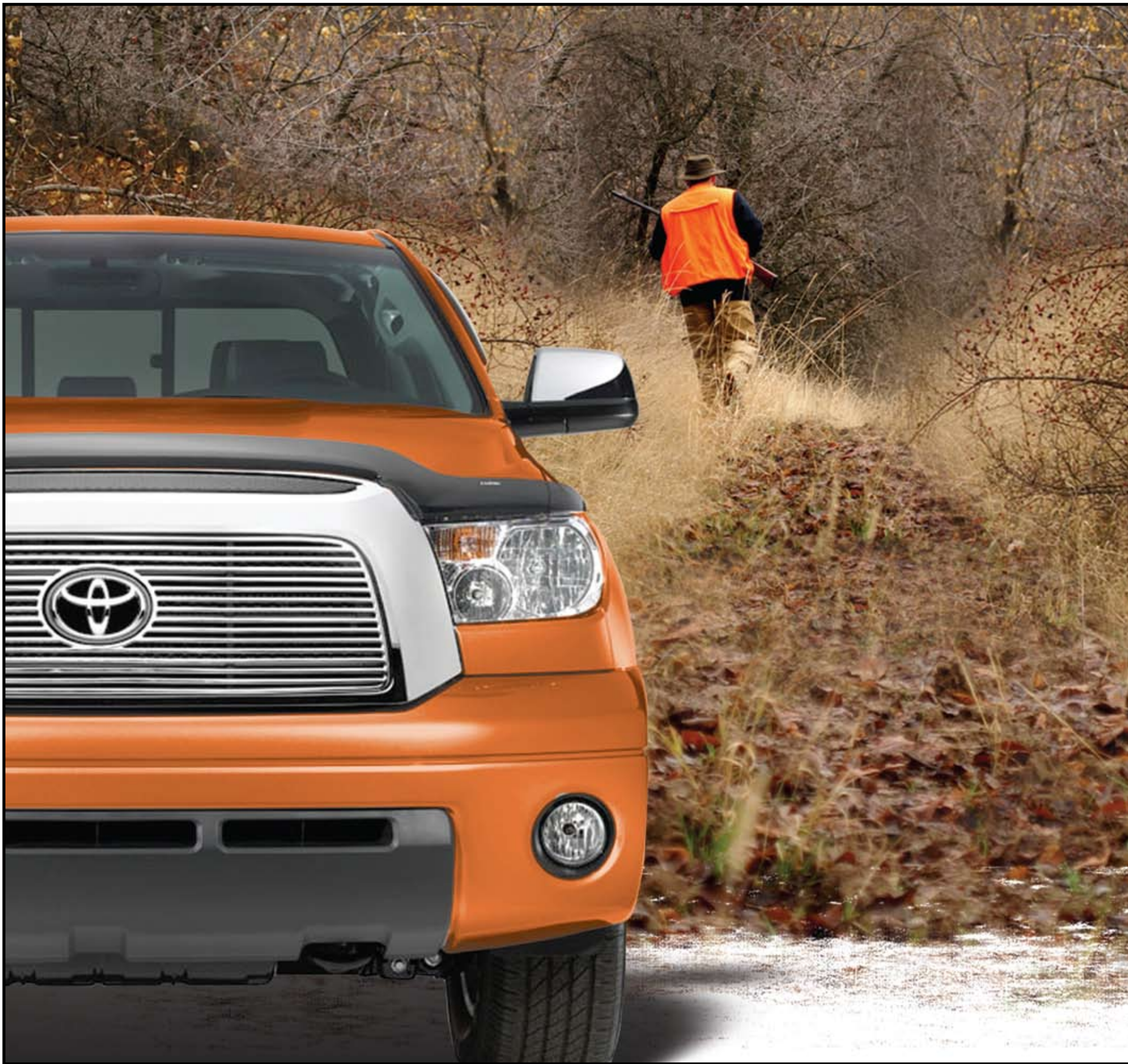

Don't settle for less than Lund.

If ever there was a "must have" vehicle accessory, this is it. Lund Hood Shields combine form and function to protect your investment with quality and style. Available in a variety of materials and designs, Lund Hood Shields look good and work hard. Whether you choose the latest TriCrylic™ polymer, traditional polycarbonate or our incomparable 304 stainless steel, wraparound or low profile, your Lund Hood Shield will install in minutes, fit perfectly and look great for years to come. When it comes to protecting your vehicle, don't settle for less than Lund. The best value in Hood Shields.

LUND HOODSHIELDS

304 Stainless	STAINLESS INTERCEPTOR™
TriCrylic Polymer	INTERCEPTOR™ II
Smoke or Clear	INTERCEPTOR™
Low Profile	AVENGER™





STAINLESS INTERCEPTOR™

304 Stainless Steel Construction

- Heavy-duty 304 stainless steel construction for excellent corrosion protection
- Full-height wrap-around design provides maximum hood, fender and windshield protection
- Application-specific designs for a custom fit
- Mounts away from hood for easy cleaning

Styling Tip:

Enhance the look" with a **LUND BILLET GRILLE** (pages 4-12)

**HEAVY-DUTY
STAINLESS STEEL**

STAINLESS INTERCEPTOR™

INTERCEPTOR™ II

INTERCEPTOR™

AVENGER™



Tough and Light

INTERCEPTOR™ II

- Advanced TriCrylic™ polymer material is tough and light
- Full height wrap-around design provides maximum hood, fender and windshield protection
- Application-specific designs for a custom fit
- Mounts away from hood for easy cleaning
- Semi opaque smoke finish provides a unique, attractive appearance

Styling Tip:

Don't forget to add a set of **LUND WINDOW VENTS** (pages 20-21)

TRICRYLIC™ POLYMER

STAINLESS INTERCEPTOR™

INTERCEPTOR™ II

INTERCEPTOR™

AVENGER™



INTERCEPTOR™

Full Height, Wrap-Around Design

STAINLESS INTERCEPTOR™

INTERCEPTOR™ II

INTERCEPTOR™

AVENGER™

- Full-height wrap-around design provides maximum hood, fender and windshield protection
- Polycarbonate material is virtually unbreakable
- Available in smoke or paintable clear
- Mounts away from hood for easy cleaning

Styling Tip:

Check out our complete selection of **RUNNING BOARDS** (pages 40-53)

SMOKE FINISH or PAINT TO MATCH



Low Profile

AVENGER™

STAINLESS INTERCEPTOR™

INTERCEPTOR™ II

INTERCEPTOR™

AVENGER™

- Aerodynamic, low profile design engineered to closely match contours of each hood
- Polycarbonate material is virtually unbreakable
- Smoke finish provides stylish functionality
- Easy to Install

Styling Tip:

Don't forget to add a set of **LUND WINDOW VENTS** (pages 20-21)

LOW PROFILE

LUND HOOD SCOOPS



Creates a simulated "Performance Hood" look

Lund Hood Scoops are the perfect way to add a performance look to your ride without performing major hood surgery. They're easy to install and can be painted to match your vehicle.

- Unique stylized hood scoops for trucks and cars
- Transform stock hood into a simulated "performance hood"
- Durable, heat resistant high impact ABS material
- No drill installation — mounts with concealed 3M adhesive foam tape
- Easily painted to match factory color



Five sizes: Large single, Small single, truck cowl induction, medium pair and large pair

2 1/2" x 13" x 28"

LARGE SINGLE



LUND HOOD SCOOPS

2 1/2" x 13" x 28"

MEDIUM PAIR



2 1/2" x 13 1/2" x 35"

LARGE PAIR

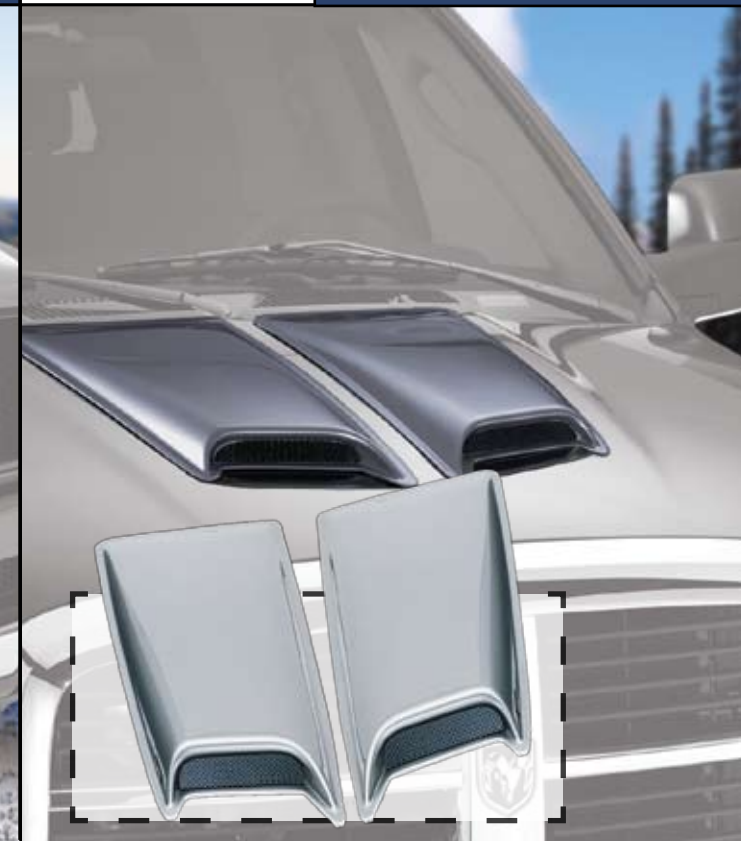

2" x 13 1/2" x 18 1/4"

SMALL SINGLE



22 1/4" x 29 1/4"

TRUCK COWL INDUCTION





The industry standard for more than 30 years

A Lund Visor will make your truck, SUV or CUV look great, but there's a lot more to it than that. In addition to adding a customized look to your vehicle, Lund visors are designed to reduce glare.. They're also designed to be easy to install. Some Lund Visors include running lights to enhance both looks and safety. All are easy to paint to match your vehicle with black ABS construction or a smooth gelcoat finished fiberglass.

Don't settle for anything but the best for your ride. Lund Visors are truly a case of form following function.



Lund's Original Visor

SUNVISOR®



- Patented airflow design for improved aerodynamics
- Provides glare reduction
- Mounts to cab roof with self-tapping screws
- Custom designed to fit most domestic and imported pickups, vans, SUVs and CUVs.
- Easy to paint white gelcoat finish
- Solid fiberglass construction

Lighted Visor

MOONVISOR®

Rounded Visor

SUNVISOR™ II



- Same unique features as the **Lund SunVisor®** with the addition of recessed running lights for night safety and great looks.
- Recessed running lights provide safety and great looks
- Easy to replace light bulbs
- Wiring harness is easy to install and is concealed under lip of visor
- Solid fiberglass construction

- Patented, rounded design complements today's new vehicles
- Provides glare reduction
- Easy to paint white gelcoat finish
- Durable, solid fiberglass construction
- Custom fit for each application
- Optional Euro Style LED light kit sold separately

Sleek Visor

SOLAR®

Lighted Visor

LUNAR®



- The first visor design to match the contoured lines of today's aerodynamic vehicles.
- Hidden mounting points for a sleek factory appearance
- Constructed of durable ABS for years of performance
- Easily painted using standard automotive paint techniques

- Recessed running lights add great looks without exposed wires
- Installs with brackets customized for each vehicle application
- Rigid black ABS construction is durable and easy to paint
- Patented concealed mounting system



Keeps Rain Out — Lets Fresh Air In

- Reduces heat by allowing windows to be left partially open when parked
- Keeps rain out while letting fresh air in
- Fast and easy “no drill” installation with automotive grade tape
- Enhances the look of your vehicle
- Can be painted to match vehicle color
- Smoke finish is attractive and resists scratching
- In-channel mounting vents available



WINDOW VENTS

IN-CHANNEL WINDOW VENTS



- Reduces heat by allowing windows to be kept partially open when parked
- Keeps rain out and lets fresh air in
- Fast and easy no drill installation with strong automotive grade tape
- Available in popular smoke color
- Two piece or four piece sets available

- Sleek, streamlined appearance - no exterior tape touches the vehicle
- Greater visibility - no “leg” to obstruct the side view mirror
- Decreased wind noise
- Fast and easy, no drill installation
- Available in popular smoke color

Hot customized look for extended cab pickups

SIDE WINDOW COVERS



Solid Style

Cut Out Style

- Available in solid or cut-out style
- Easy no drill installation with automotive grade adhesive tape
- Available in popular smoke color — can be painted to match vehicle

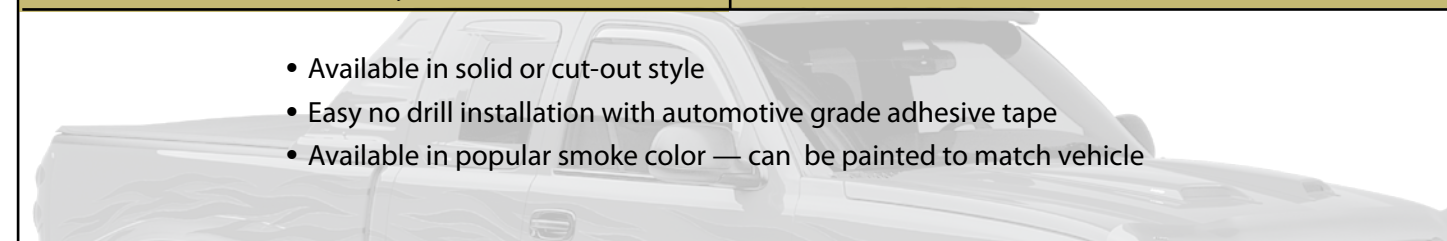

LUND CAB FAIRINGS and AIR DEFLECTORS



Cab Fairing

RUGGED SERIES

Lund Cab Fairings and Air Deflectors are an inexpensive and easy way to give your vehicle a sleek, highly-customized look while enhancing your driving experience. Cab fairings extend the lines of your truck's cab and provide protection from the sun. The Windjammer Air Deflector keeps your rear window cleaner and our Shadow Wiper Cowl protects your wipers.

Add a Lund Hoodshield, Window Vents and Tonneau Cover and you've really got the look!





- Brushed aluminum rails and heavy duty cab fairing create an exciting new look
- Two fixed and four adjustable 200 lb. capacity anchors provide functional tie-down system
- Ready to install, UV resistant ABS with textured black finish can also be painted to match vehicle
- Reduces sun glare and shades cab



Integrated bed rails work with Genesis™ Roll Up Tonneau



LUND CAB FAIRINGS and AIR DEFLECTORS

Cab Fairing	RACERBACK™	Cab Fairing	FASTBACK™
	<ul style="list-style-type: none"> • Patented design extends cab lines for a fast racing look. • Shields rear window and cargo area from the sun • Attaches to truck cab only — fits with most tonneau covers • Makes an ideal light bar • Solid fiberglass construction 		<ul style="list-style-type: none"> • Patented design extends the lines of the cab and acts as a sun shade • Gives an aerodynamic racing look to pickups • Available with high mounted third brake light • Easy to paint white gelcoat finish • Attaches to truck bed only • Solid fiberglass construction
			

Rear Window Air Deflector	WINDJAMMER™	Wiper Cowl	SHADOW™
	<ul style="list-style-type: none"> • Designed to help keep rear window clear of debris • Styled to match lines of roof and hatch • Easy to install with automotive grade adhesive tape and/or screws • Designed to work with all third brake lights • Impact resistant ABS construction 		<ul style="list-style-type: none"> • Provides a custom, chopped look for trucks • Hides and protects wiper area • Easy to install with 3M™ Dual-Loc tape and/or screws • Custom fit styles available for most pickups and sport utility vehicles
			



Real Experts Choose Lund Tonneau Covers

In addition to protecting your truck bed and hiding its contents, tonneau covers are proven to reduce drag and increase miles-per-gallon. Talk to more than one pickup owner, however, and they may not agree on which style of tonneau cover is the best. Our top of the line Roll Ups virtually disappear when rolled back, the Tri-Folds flip effortlessly out of the way, Snaps offer proven bed protection, Seal & Peel opens and closes quickly and seals completely and the Hinged tonneaus are easy to open with one hand operation.

No matter which style they recommend, real experts always go with Lund. That's because Lund Tonneau Covers are easy to install and built to last and last. Whatever style you prefer, there's a Lund Tonneau Cover to fit your truck and your lifestyle.

LUND TONNEAUS

Virtually Disappears	GENESIS ROLL UP TONNEAU
Installs in Minutes	GENESIS TRI-FOLD TONNEAU
Proven Bed Protection	GENESIS SNAP TONNEAU
Opens & Closes Quickly	GENESIS SEAL & PEEL TONNEAU
One Hand Operation	GENESIS HINGED TONNEAU





GENESIS™ ROLL UP TONNEAU

Virtually Disappears when Rolled Back



Double-sided tear resistant fabric with unmatched low profile design (black matte finish)



Dual latches with built in adjustment gauges +/- arrows provide for perfect alignment and tension control



Quick release rear rail provides easy opening and closing

- Easy, no drill installation in under 20 minutes
- Heavy duty black rails and bows provide easy operation
- Unique corner caps on rail protect corners provide a low profile fit and finish
- Heavy-duty velcro hook and loop fastener measuring 1.5 inches wide is securely fixed to each side rail with durable adhesive allowing for easy opening and closing
- Integrated multi-finned rubber seal on both front and rear rails provide a solid barrier from dirt and moisture



Installs in Minutes

GENESIS™ TRI-FOLD TONNEAU

- Pre-assembled for an easy, no drill installation in under 5 minutes
- Easy Accessibility
- Heavy duty, black rails and bows provide easy operation and proven durability
- Secure, buckle style closure straps easily hold cover in open position



Low profile design with double-sided tear resistant fabric (black matte finish)



Quick release cam latches provide tension and security



Folds up in seconds and is secured with heavy duty buckle straps

Can be shipped UPS

Limited lifetime warranty on frame and cover



GENESIS™ SNAP TONNEAU

Proven Protection



Patented Insulsnaps™ slide within rail to provide easy cover alignment and prevent rust and corrosion

No drill clamp installation. Clamps and rails are padded to protect truck bed

- Installs in 20 minutes
- Heavy duty bows and rails prevent water and snow build up
- Integrated rear tailgate seal will not get knocked off like adhesive seals
- Front corner snap to allow easy access to cargo behind cab

Limited lifetime warranty on frame and cover

Can be shipped UPS



Easy to Open and Close

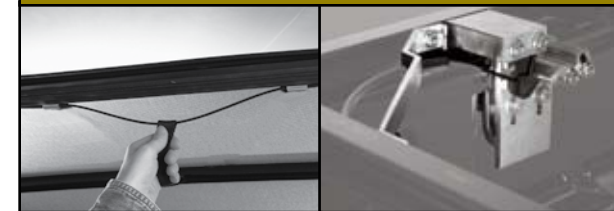

One Hand Operation

Heavy Duty Slam-N-Scram™ latch provides instant latching

- Hinged design allows complete and easy access to truck bed
- Pre-marked rails and heavy-duty clamps assure quick, no drill installation
- Heavy duty gas struts provide quick, one hand opening

Can be shipped UPS

Limited lifetime warranty on frame and cover

GENESIS™ HINGED TONNEAU



GENESIS™ SEAL & PEEL TONNEAU

Opens & Closes Quickly



Snapless closure system opens & closes quickly and seals completely

Integrated rear tailgate seal

- Pre-marked rail and heavy duty clamps assure quick, no drill installation
- Superbly engineered cover and rails provide a perfect, no adjustment fit in extreme climates.
- Integrated rear tailgate seal will not get knocked off like adhesive seals

Limited lifetime warranty on frame and cover

Can be shipped UPS

Installs with automotive grade adhesive tape



- Extruded rubber seal prevents dust and moisture from entering truck bed
- Design fits most makes and models
- High quality EPDM rubber stands up to the elements
- 3M™ adhesive tape for easy installation

Can be shipped UPS

GENESIS™ TAILGATE SEAL





Get a Leg Up on Style

Everyone knows there are two reasons people put running boards on their truck, SUV or CUV: style and function. At Lund, we engineer every running board to superbly suit its purpose, so no matter which style you choose; your new running boards will be easy to install, strong and built to last.

Lund's unique multi-fit running boards and brackets significantly reduce inventory requirements so they are as easy to buy as they are to install.

So now, your choice is down to style alone. And, with nearly 20 distinctive designs to choose from, you may have a hard time deciding which is best for you and your ride. The bottom line: there's a set of Lund Running Boards that's perfect for your vehicle and your lifestyle.

LUND RUNNING BOARDS

MULTI-FIT RUNNING BOARDS

- Unique multi-fit running boards and brackets significantly reduce inventory requirements so they are as easy to buy as they are to install
- All boards are available in a variety of lengths
- Easy to install, no drill installation system utilizes custom fit brackets



Tube Step - Chrome



Tube Step - Black Powder Coat



Factory Style Lighted



StepRails™ Black



Factory Style Non Lighted



StepRails™ Brite



TrailRunner™ Diamond Plate



RadStep™ Paintable Shell



TrailRunner™ Black



RadStep™ Paintable Shell



TrailRunner™ Brite



Rugged™ Series

All boards are available in a variety of lengths for a custom fit appearance

OE Style No Drill Bracket



- Constructed of 12-gauge steel for full support
- Part number included on each bracket for easy identification
- Wide, sturdy design with a black powder coat finish for an unbeatable rugged look



100% no drill applications

MULTI-FIT

(Works with all Lund Multi-Fit Running Boards)

EZ Bracket™ Custom Fit Mounting Kits

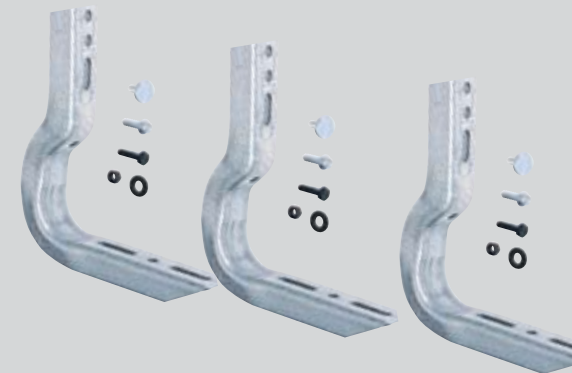

- Heavy duty "U channel" steel construction
- Custom fit moulding kits for each application



Several no drill applications available

MULTI-FIT BRACKETS



TUBE STEP

Chrome or Black Powder Coat



- Ultra wide, stylish 5" oval tube design
- Fast, easy no drill installation with 'OE Style Bracket' (sold separately)
- Comes completely assembled out of the box
- Multi-fit board designs reduce inventory — only brackets are application specific
- Attractive chrome and black powder coat finishes available to fit your style
- Aluminum construction provides durability and resists corrosion
- Stylish step tread design provides sure-footing



Four lengths available for a custom fit:
54", 70", 80" and 90"

MULTI-FIT



Molded Running Boards

FACTORY STYLE

- Heavy duty, durable polymer material with full step aluminum support
- Lighted or non-lighted options
- Four multi-fit lengths (52", 70", 80" and 90")
- May be used with Lund's OE Style No Drill Bracket or EZ Bracket™ (sold separately)



Lighted option includes deck lights, marker lights (amber) and turn signal lights



MULTI-FIT



RUGGED™ SERIES

Molded Running Boards

- Rugged, ABS molded board with diamond pattern step tread and full aluminum support
- Four multi-fit lengths (54", 70", 80" and 90")
- May be used with Lund's OE Style No Drill Bracket or EZ Bracket™ (sold separately)



Rugged, ABS molded board with diamond pattern step tread



ABS can be installed as is or painted to match vehicle

MULTI-FIT



Elliptical Aluminum Steps

RADSTEP™

- Heavy duty extruded aluminum step in a radical, elliptical design
- Textured black or paintable ABS shell covers the ends of the step
- Three multi-fit lengths (70", 80" and 90")
- Styled rubber step tread is integrated into ABS cover and provides sure footing
- Available for many SUVs, extended cab and crew cab trucks
- May be used with Lund's OE Style No Drill Bracket or EZ Bracket™ (sold separately)



Integrated rubber step tread



Heavy duty, extruded aluminum

MULTI-FIT



STEPRAILS™

Elliptical Aluminum Running Boards



24" length for standard cab pickups

- Heavy duty, rugged tubular appearance
- Durable aluminum construction will not rust or corrode
- Thick, non-slip step treads
- Five multi-fit lengths (24", 54", 70", 80" and 90")
- Available in black or brite finish - no painting required for installation



End caps adjust allowing board length to be altered for custom fit

MULTI-FIT



Aluminum Running Boards

TRAILRUNNER™

- Available in rugged diamond plate aluminum design - brite finish, and in rugged extruded designs - brite and black finishes
- Wide step area for sure footing
- Molded end caps for a finished look
- Four multi-fit lengths (54", 70", 80", and 90") for standard and extended cab pickups and popular SUVs



MULTI-FIT





TRAILBACK™

Stylish and Functional

High Impact Step Pad

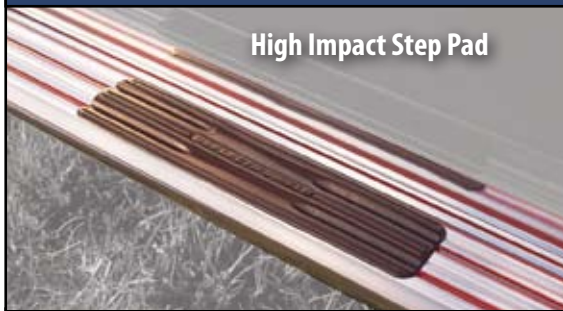

- Unique, tubular shaped aluminum extrusion provides a high end, attractive appearance
- Available in brite or popular black anodized finish which maintains its shine under the toughest conditions
- Raised, serrated stepping surface runs the entire length of board providing maximum traction
- Molded, high impact step pads provide safe, secure footing
- Matching contoured mud flaps and end caps complete the aerodynamic design while providing superior protection from road debris.

Contoured Mud Flap



Molded End Cap

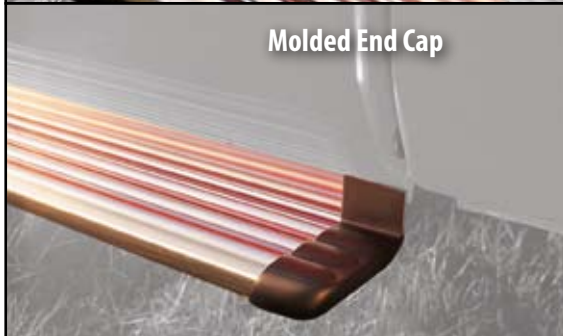

Body-Mount™ Installation System

Factory recommended Body-Mount™ Installation System keeps body and frame separate, eliminating vibration and road noise. Installation time can be reduced by 50% without the need for frame drilling. The result is a solid, professional, noise-free installation.

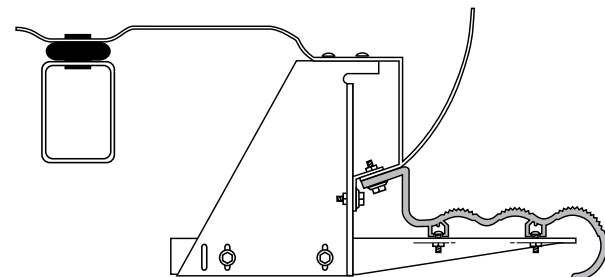

Body-Mount™ Installation System

Delta III™ and Challenger™ running boards utilize our exclusive, custom Body-Mount™ System with galvanized steel brackets. The Body-Mount System keeps body and frame separate, eliminating the extra stress, wear and road noise caused by competitive frame mount systems.

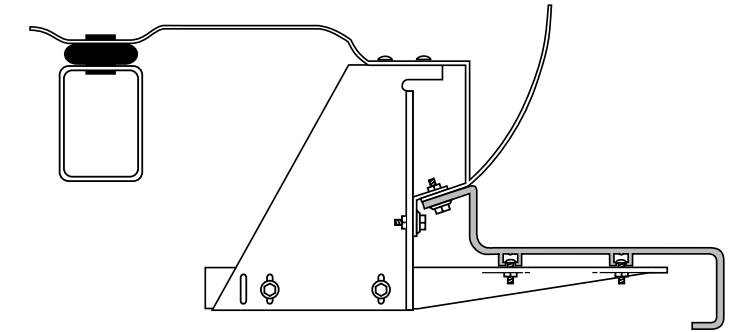

Extruded Aluminum

- Heavy-gauge, extruded aluminum construction provides traditional styling and strength
- Large stone guards prevent rocker panel damage from road debris
- Grit tape along the entire surface of the board provides secure footing
- Custom, Body-Mount™ bracket system keeps truck cab and frame separate, reducing road noise, squeaks and stress
- Available in full length and 2-piece applications

DELTA III™



Durable with rugged good looks

- Rugged and durable diamond plate aluminum construction provides secure footing
- Large stone guards prevent rocker panel damage from road debris
- Custom, Body-Mount™ bracket system keeps truck cab and frame separate, reducing road noise, squeaks and stress
- Available in full length and 2-piece applications

CHALLENGER™





SUPERSTEP™

Universal Truck Step

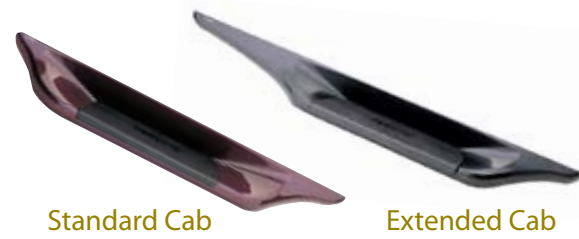

- Features heavy duty, rust-proof steel brackets and wrap around rubber step tread.
- Provides easy one step entry into most vehicles
- Comes in ready-to-install black finish or may be painted to match vehicle
- Rigid molded black polymer construction



Universal Running Boards



- Six SKUs cover more than 40 models of trucks and SUVs
- Heavy duty galvanized steel support brackets
- Ready to install black finish or can be painted to match vehicle
- Rigid molded black polymer construction



Full length step area for front and rear doors of SUV and some extended cab pickups



RUNNERS™

Molded Tubular Truck Steps



Radically styled, impact resistant, ABS plastic shell

- Rugged tubular steel body mount bracketry, powder coated for durability
- Two SKUs fit more than 40 models
- Includes all mounting hardware
- Available in black or can be painted to match vehicle



Custom Fiberglass Truck & SUV Steps

- Custom designed for each application
- Extra wide deep step pads for easy access
- Rugged, factory recommended body mounted bracket system keeps body and frame separate to reduce road noise and vibration
- Rust resistant steel brackets and support plates provide strength to support an adult's weight along entire step area
- Most installations require no drilling in exposed vehicle surfaces including rocker panels
- Durable solid fiberglass construction with ready-to-paint white gelcoat finish



X-STEP™



The next generation in truck steps with smooth, sculpted lines to blend with current vehicle styles



You CAN Take it With You

When the question is: Do I take the camping equipment or the kids? - You need an easy, fast and inexpensive way to add cargo carrying capabilities to your car, truck, CUV or SUV. With Lund's cargo management solutions, you'll never face such a dilemma. Need more capacity? Add a Roof Top Cargo Rack, Hitch-Mounted Cargo Carrier or Aero Bag. Need a longer truck bed for work or play? Get a HitchRack™.

Even if you need help getting a load into your truck, Lund has the solution. Our folding ramps are strong, easy to use and travel right along with you. We can even help you keep groceries and other cargo in place with our unique Cargo Logic® System that includes Cargo Loks® and a handy Tote to firmly hold items steady, avoiding spills.

Now, there's no need to drive a full-size SUV or truck every day because you occasionally need to carry extra cargo. Lund's cargo management solutions give your car, van or CUV the extra capacity you need only when you need it. So, no matter what type of vehicle you drive, when it comes to cargo, you really CAN take it with you.

LUND CARGO MANAGEMENT





HITCHRACK

The Truck Bed Extender

- Unique hitch mount design allows you to carry extended length cargo safely and securely
- Box steel construction provides up to 750 lbs. distributed load capacity
- Durable and easy to use
- Support arms adjust from 30" to 50" wide
- 4-way adjustable



Support structure adjusts vertically to support roof-mounted articles on SUV, CUV, truck or van



Side supports fold down to create portable sawhorse or worktable

Bike Carrier Accessories

- Constructed of 2" steel tubing and powder coated for durability and rust protection
- Folds down and away to allow easy access to rear of vehicle
- Locking knob for added security
- Adjustable clamp plate fits most tube frame diameters
- Rubber padding on clamp prevents slipping and scratching of bikes
- Built-in anti-wobble system



+2 Bike Add On

- Increases capacity of your bike carrier
- Easy no-drill attachment

Bike Adapter

- Carry women's, children's, and other y-bike frames
- Clamps under seat and handlebars and locks into place

DROP DOWN BIKE CARRIER



Carry Two Bikes Securely

- Versatile design attaches to **Do it Yourself Cargo Carrier** or fits into standard 1-1/4" receiver hitch
- Rubberized coating on cradle prevents slipping and scratching of bikes
- Heavy gauge steel tubing for strength and durability
- Securely carries two bikes
- Adjustable clamp accommodates most frame tube diameters
- Anti-theft cradle has hole for attaching standard padlock (sold separately)

DUAL BIKE CARRIER





ROOF TOP CARGO RACK



Large Capacity Cargo Basket



- Cargo basket attaches to factory or aftermarket roof racks with no drilling
- Large capacity basket provides plenty of storage space for luggage, cargo bags, and more
- Two sizes (39" x 44" and 39" x 55") fit most vehicles
- Constructed from powder coated thin-wall steel for lightweight durability



Waterproof Rooftop Carrier

- Complete weatherproof protection in an aerodynamic design
- Sloped front deflects water and air up and over the bag
- Constructed of durable fiberglass reinforced waterproof material with heat sealed seams
- Lightweight, with more than 11 cubic feet of storage capacity
- Attaches with heavy duty straps to existing roof rack or cargo rack with no drilling

AERO BAG



ROOF RACK CARGO NETTING



Secure Cargo

- Easily secures cargo to the Roof Top Cargo Rack
- Durable design with reinforced hooks make packing cargo a breeze
- Attaches in seconds and holds securely

Lightweight Roof Top Bag

- Nylon and polyester bag is easy to install with quick attach web straps
- Folds neatly away for storage when not in use
- Full length, 2-way zippers provide easy access and loading from sides or back
- Lightweight, large capacity design stores up to 13 cubic feet of cargo
- Attaches to factory or aftermarket roof racks with no drilling

SOFT PACK





HITCH-MOUNTED CARGO CARRIERS



Stationary Style
Available in 20" x 60" steel platform



Folding Style
Available in 21" x 61" and 21" x 48" steel platform

Hitch Mount Designs

- Hitch-mounted design for quick install
- Pre-punched holes for attaching accessories and tie down straps
- 500 lb. distributed load capacity
- Durable, black powder coated steel construction
- Compact design ships UPS
- Folding and Stationary styles available



Fits into standard 2" receiver.
Receiver pin not included.

DO IT YOURSELF CARGO CARRIER KIT



Easy DIY Solution

- Attaches to self-supplied plywood or aluminum tray (sold separately) to complete your own cargo carrier
- Heavy gauge steel construction
- 500 lb. distributed load capacity
- Easy assembly and installation
- Installs in standard 2" tow receiver hitches
- Pre-drilled holes for attaching accessories and bungee strap



Transport Cargo with Confidence

- Waterproof PVC dry storage bag protects your belongings
- Heat sealed seams and reinforced zipper flaps keep the weather out
- Works with **Hitch-Mounted Cargo Carrier**
- Durable polypropylene straps secure the bag to the carrier
- Holds more than 11 cubic feet of cargo

CARGO CARRIER ACCESSORIES

Heavy Duty Storage Bag



- Easily attaches to the carrier to help restrain cargo
- Durable, black powder coated steel for strength and long life
- For use with stationary style carrier only

Side Bar Attachment



- Easily secures cargo to the **Hitch-Mounted Cargo Carrier**
- Durable Design with reinforced hooks makes packing cargo a breeze
- Installs in seconds

Cargo Netting



- Allows you to carry up to three bikes on the **Hitch-Mounted Cargo Carrier**
- Front tire slips into loop and is secured with tie down straps (not included)
- Durable, black powder coated steel for strength and long life

Bike Carrier Attachment





CARGO BARS

Stops Cargo from Shifting

Telescoping Cargo Bar



- Stops cargo from shifting in pickup trucks, SUVs and CUVs
- Telescopic design adjusts from 47" to 70"
- Rubber ends will not scrape cargo area

Telescoping Cargo Bar with Net



- Same great features as the **Telescoping Cargo Bar**
- Includes a heavy duty net
- Easy to use, no tools required

Ratcheting Cargo Bar



- Stops cargo from shifting in pickup trucks, SUVs and CUVs
- Ratcheting adjustment design is fully expandable from 40" to 70"
- Rubber ends will not scrape cargo area and secures cargo bar tightly to wall of vehicle
- Easy to use, no tools required

HITCHSTEP™

Easy fold up design

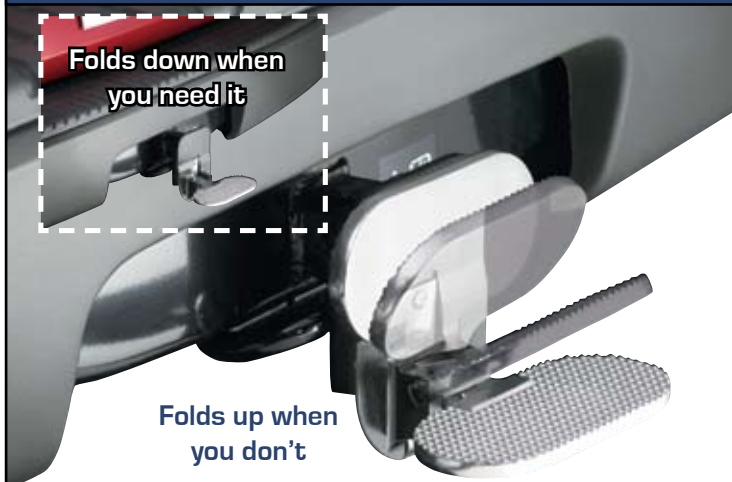

- Provides easy access to back roof of SUV or Minivan
- Attaches quickly to any 2" receiver hitch — no drilling
- Constructed of durable die-cast aluminum for long life
- Folds down when you need it — up when you don't
- Slip resistant stepping surface



Durable and Lightweight

- 750 lb. distributed load capacity per section — up to 50% more than competitive products
- Flat, extruded hole surface provides traction, easy loading and accommodates all wheel sizes
- 30" x 69" and 30" x 77" Bi-Fold designs fold to 15-inch width and can be taken apart
- Aluminum construction is rust resistant, durable and lightweight
- Rubber angle protector to protect tailgate
- Nylon safety straps secure ramps to vehicle to prevent shifting
- Angled foot provides smooth transition from ground to ramp
- Three year limited warranty

BI-FOLD RAMP



Bonus features found on 77-inch ramp:

Patent pending tailgate angle pivots vertically to fit flush with tailgate to accommodate various heights
Additional 8-inch length provides lower level of incline

Easy Loading

- 750 lb. distributed load capacity per section provides up to 30% more capacity than competitive products
- Flat, extruded hole surface provides traction, easy loading and accommodates all wheel sizes
- 45" x 69" and 46" x 77" Tri-Fold design folds to 15-inch width for easy transport
- Aluminum construction is rust resistant, durable and lightweight
- Rubber angle protector to protect tailgate
- Nylon safety straps secure ramps to vehicle to prevent shifting
- Angled foot provides smooth transition from ground to ramp
- Three year limited warranty

TRI-FOLD RAMP



Bonus features found on 77-inch ramp:

Patent pending tailgate angle pivots vertically to fit flush with tailgate to accommodate various heights
Additional 8-inch length provides lower level of incline

FOLDING ALUMINUM RAMP



- Heavy duty design — 1,000 lb. distributed load capacity per ramp
- Extremely lightweight (17 lbs.) for easy use
- 12 3/8" x 87 5/8" design folds in half with carrying handle for convenient storage
- Flat, extruded hole surface provides traction and easy loading
- Raised edges help keep wheels on ramp surface
- Rubberized tailgate protector protects truck gate finish
- Sold individually (one ramp per box)
- Patented design
- Three year limited warranty

FOLDING ALUMINUM ARCHED RAMP



- Arched and extra long for easier loading of lawn tractors and other equipment
- Heavy duty design — 750 lb. distributed load capacity per ramp
- 12 3/8" x 118" design folds in half with carrying handle for convenient storage
- Flat, extruded hole surface provides traction and easy loading
- Raised edges help keep wheels on ramp surface
- Rubberized tailgate protector protects truck gate finish
- Sold individually (one ramp per box)
- Patented design
- Three year limited warranty

RAMP KIT



- Attaches to 2" x 8" or 2" x 10" wood planks to create an economical set of ramps (wood planks sold separately)
- All hardware included for easy installation
- Sold in sets of 2
- Three year limited warranty

BI-FOLD LADDER RAMP

- Heavy duty design — 750 lb. distributed load capacity
- Ladder style surface for superior traction
- Aluminum construction is rust resistant, durable and lightweight
- Folds for easy storage
- More rungs for added strength
- Rubber coating protects tailgate from scratching
- Nylon safety straps secure ramps to vehicle to prevent shifting



- Aluminum construction is rust resistant, durable and lightweight
- 750 lb. distributed load capacity
- Folds for easy storage
- Rubber coating protects tailgate from scratching
- Nylon safety straps secure ramp to vehicle to prevent shifting

TRI-FOLD LADDER RAMP

Need image of Tri-Fold ladder ramp



CARGO • LOGIC®

Total Cargo Area Protection

- Durable stain proof looped polyware surface looks like carpet, but it's not
- Heavy duty thermoplastic liner protects from dirt, mud, snow and water
- Stain resistant protection — simply hoses off for easy cleaning
- Scuff and scratch resistant surface, pet friendly
- Raised lip contains spills
- Custom molded to fit contours of vehicle
- Limited lifetime warranty not to crack or break



Cargo-Loks provide cargo stability (set of two included)



Simply hoses off for easy cleaning

Cargo Stability

CARGO-LOKS



Velcro hooks hold Cargo-Loks in place



Easily reposition the Loks to protect just about anything

The Perfect Storage and Travel Catch

CARGO LOGIC® TOTE

- Stores flat and pops up when needed to keep items neat and secure
- Removable dividers included to compartmentalize your cargo
- Easily transport groceries and other items with two carrying handles
- Tough outer fabric is water resistant and durable
- Rigid plastic inner panels holds items upright
- Universal design fits most vehicles and can be used with our **Cargo • Logic Liner and Cargo • Loks** for added protection and security





Protect Your Investment with Strength and Beauty

Until recently, protecting the carpeting in your truck, CUV, SUV or car meant throwing in a set of rubber floor mats and hoping for the best. It was a lot like putting plastic covers on your brand new furniture, effective, but lacking style. At Lund, we knew we could do better, so we created Catch-All™, and Catch-All Plus™ -- superior floor protection that actually looks good.

Next, for hardcore vehicular slobs (you know who you are), we developed the Xtreme™ series. Designed for severe environments where average carpet protection solutions dare not tread, our Xtreme™ Catch-All™ and Xtreme™ Catch-All Plus™ floor protection solutions are made of Xynet™, a revolutionary thermoplastic material that resists virtually anything your feet (or your kid's soccer cleats) can throw at it.

So, why not take a step beyond old fashioned, unsightly, rubber floor mats? Protect your investment with Lund and get the look.

LUND FLOOR PROTECTION



CATCH-ALL™

Premium Floor Protection



Durable moisture protection barrier



Cleans easily - simply hose off



Electronically welded heel pad

The Catch-All™ premium floor protection solution will add style and elegance while protecting your vehicle's carpet. Each set is custom molded with an exact fit for your vehicle. No need to worry about spills, the moisture barrier protects your carpet from dirt, mud, snow and water. Clean up is quick and easy. The best looking floor protection available for your vehicle.

- Plush OE nylon carpet color matched to vehicle's current model year
- Molded to fit the exact contour of the vehicle floor
- Heavy duty moisture barrier protects vehicle's carpet from dirt, mud, snow and water
- Stain resistant protection - cleans easily
- Raised lip contains spills
- Electronically welded heel pad enhances durability

Plush OE Nylon Carpet

CATCH-ALL™

Front set for driver and passenger area ----->

Second and third seat where applicable ----->
(2 piece rears available for some vehicles)

Rear cargo area ----->



Innovative One-Piece Design

CATCH-ALL™ PLUS™

The pinnacle of floor protection available in a plush OE nylon carpet. Catch-All™ Plus features a patented, one-piece design for the ultimate carpet coverage protecting the driver, passenger and center areas.

- Patented one-piece design protects the entire front floor
- Custom-molded for a perfect fit
- Installs and cleans up easily
- Features a center storage tray
- Gear shift cut-out where applicable
- Plush carpet protect and looks great



Grey Beige Charcoal



Xtreme™ Catch-All™ is made from Xynet™, a revolutionary custom molded thermoplastic material, for heavy duty floor protection in any extreme environment. Xynet™ is a custom formulated resin compound with the look and feel of rubber. It is resistant to water, snow, dirt, mud, grease and chemicals. Xynet™ is thicker and heavier than the materials used in competitive molded products.

XTREME™ CATCH-ALL

Floor Protection with an Attitude

- Custom molded to each vehicle for a perfect fit
- Covers maximum floor area for extreme protection
- Slip resistant surface is designed to minimize shifting of cargo and other objects
- Patented snap fastener system secures the Xtreme™ Catch-All™ in place and ensures stability under foot
- Patented molded outer edge creates a virtually impenetrable barrier preventing debris and moisture from reaching your vehicle's carpeting or flooring
- Easy to clean - Simply hose off and wipe dry



Front Seat Area



Second / Third Seat Area



Rear Cargo Area

Durable Thermoplastic

XTREME™ CATCH-ALL™ PLUS™

Textured non-slip finish simply hoses off for easy cleaning

Patented snap fastener system

Grommet attaches to factory floor hook (where applicable)



Innovative One-Piece Design

XTREME™ CATCH-ALL™ PLUS™

- Innovative one-piece design for maximum floor protection
- Custom molded for a perfect fit
- Durable Xynet™ thermoplastic compound provides nonslip textured surface
- Raised outer wall contains spills, dirt and moisture
- Center storage tray
- Easy to install and easy to clean



Tan

Grey

Black



To Get the Best, Think Outside the Box

Whether it's a bed-mounted toolbox for your pickup, a storage box for your ATV or a tote box for hand tools, the outside of the box is just as important as the inside. That's because, to do the job, a storage box must fit both your vehicle and your needs. Now, Deflecta-Shield, the storage box brand you've trusted for more than 20 years, is part of the Lund family of quality accessories.

From the budget-minded Contender™, to the industrial grade Seal-Tite™, Lund Storage Boxes are designed to keep tools and other equipment safe and secure and look great doing it. Available in diamond plate, black or polished finishes and in a wide variety of sizes, styles and designs, Lund Storage Boxes are easy to install and a pleasure to use.

So remember, to be sure your equipment is handy, safe and secure on the inside, look for Lund/Deflecta-Shield on the outside.

LUND STORAGE BOXES

Designed for Professionals	SEAL-TITE™ SERIES
Our Broadest Line	CHALLENGER™ SERIES
Heavy Duty Consumer Grade	ULTIMA™
For the Value Conscious	CONTENDER™



SEAL-TITE™ SERIES

Heavy Duty, Industrial Grade Boxes Designed with the Features Professionals Demand

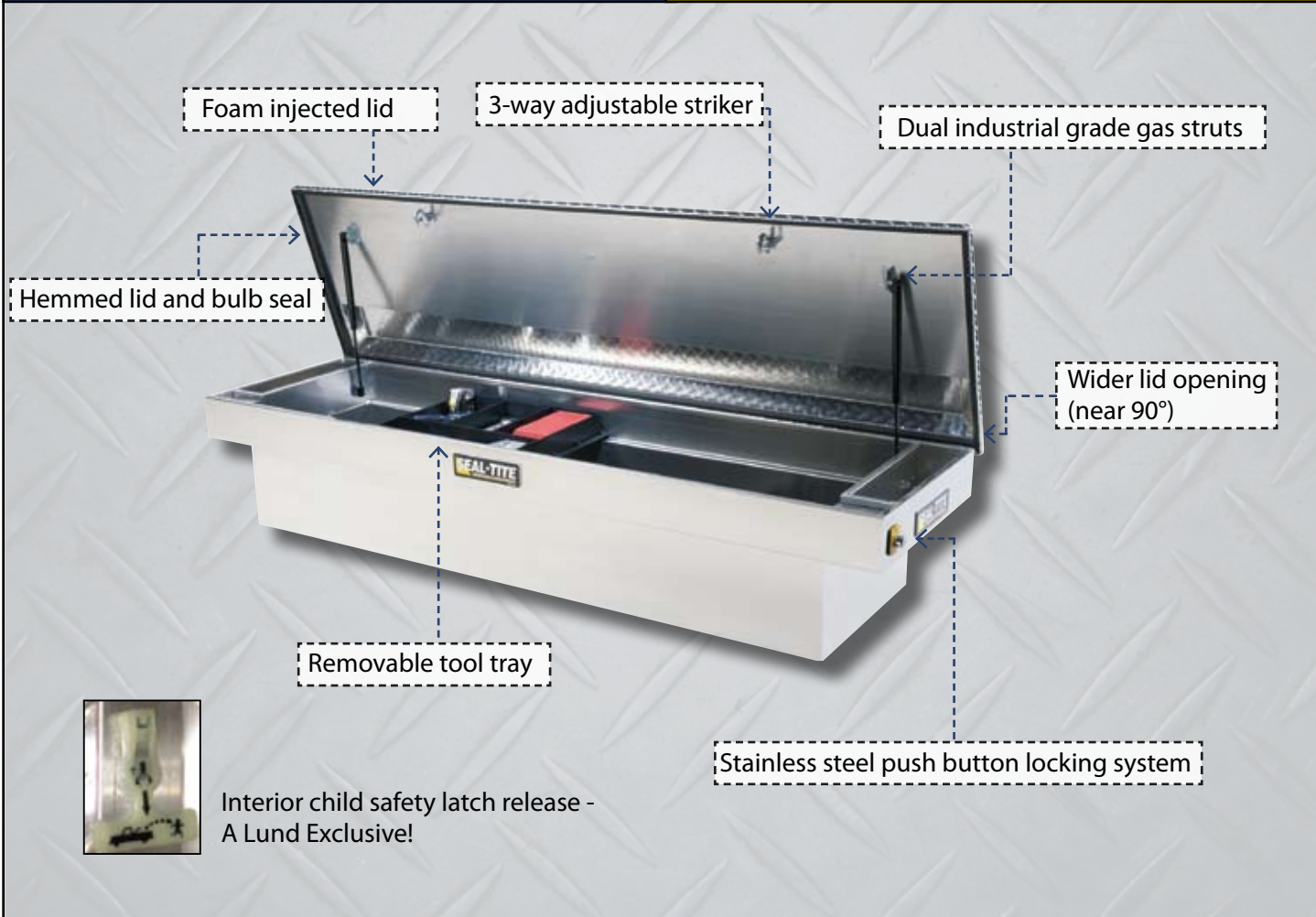

Heavy Duty, Industrial Grade Boxes Designed with the Features Professionals Demand

SEAL-TITE™ SERIES

HIGH ROOF HEMMED LID

- The original, patented, high roof style sets the standard for looks and strength
- Double reinforced interior pan, with four sided automotive style bulb seal provides weather proof protection
- Heavy duty 1-piece hinge for smooth lid operation

HEAVY DUTY BODY

- Unique, polished marine grade aluminum, or traditional diamond plate, over 40% thicker than our standard boxes
- 3-piece box construction and fully welded seams strengthen box integrity

PUSH BUTTON LOCKING SYSTEM

- Push button locking system features a heavy duty lock with triple o-ring sealing
- Internal latching rod is completely enclosed to prevent damage from shifting items

COMMERCIAL GAS STRUTS

- Dual commercial grade gas struts lift lid automatically for easy one hand use

NO DRILL INSTALLATION

- Heavy duty aluminum clamps offer no-drill installation for most applications

ADJUSTABLE LID STRIKER

- 3-way adjustable lid striker to maintain weather protection and security



Single Lid Diamond Style



Single Lid Crossover



Side Mount



RV Chest



SEAL-TITE™ SERIES

Heavy Duty, Industrial Grade Boxes Designed with the Features Professionals Demand

Unique patent pending foam reinforced lid provides increased strength, rigidity and excellent sound deadening properties



Brite Finish

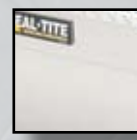

Polished Finish



Low Profile Crossover

- Ultra low profile design improves truck rear window visibility
- Rigid, foam filled lid opens to near 90 degrees
- Automotive grade rotary latch with T-handle
- Interior child safety latch release
- Plastic tool tray provides storage for small items
- Inside rubber floor mat included
- Available in diamond finish or polished finish

SEAL-TITE™ LOW PROFILE



Automotive grade rotary latch with T-handle



Low profile design improves truck rear window visibility by almost 50% versus standard height boxes



CHALLENGER™ SERIES

Our Broadest Line of Contractor Grade Boxes



Unique patent pending foam reinforced lid provides increased strength, rigidity and excellent sound deadening properties. Available on most Challenger Series.

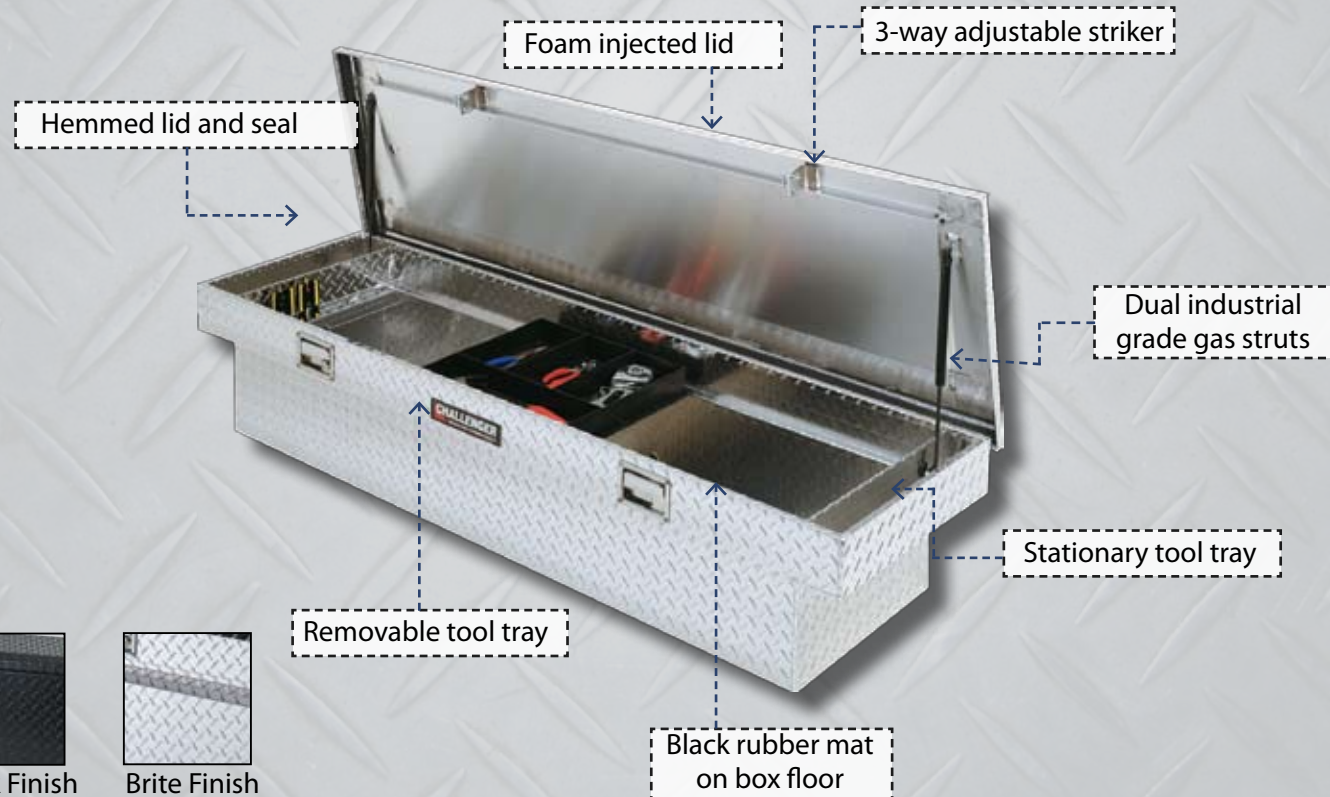

Black Finish



Brite Finish

Our Broadest Line of Construction Grade Boxes

CHALLENGER™ SERIES

FOAM INJECTED LID

- Unique patent pending foam reinforced lid provides increased strength, rigidity and excellent sound deadening properties. Available on most Challenger™ boxes

THICK DIAMOND PLATE BODY

- Extra thick high grade diamond plate body will not rust, pit or peel
- 3-piece box construction with fully welded seams provides extra strength

LEVER LOCKING SYSTEM

- Quick-release, stainless steel paddle handles offer increased security and easy lid operation from both sides of boxes

COMMERCIAL GRADE GAS STRUTS

- Twin, 45# struts provide smooth, automatic lid lifting — even in cold weather

HEAVY DUTY PLASTIC TOOL TRAY

- Deep molded tool tray provides storage for small items and sits above the ledge, allowing for maximum space inside the box

STATIONARY TRAY AND TOOL HOLDERS

- Two stationary trays, perfect for storage of small items
- Built in holders store up to 11 screwdrivers

RUBBER FLOOR MAT

- Keeps items in your box from shifting and sliding

NO DRILL INSTALLATION

- Heavy duty J-Bolt mounting hardware offers no truck bed drilling for most installations



Single Lid Crossover



Gulf Wing Crossover



C-Channel Crossover



Chest



CHALLENGER™ LOW PROFILE

Sleek Low Profile



- Heavy duty diamond plate aluminum construction
- Patent pending foam reinforced lid provides tremendous lid strength and rigidity
- Small parts storage areas, with removable plastic tool tray, built in side compartments and tool holder
- Heavy duty gas shocks lift lid automatically
- Full length latch and rod covers protect latches from damage
- Stainless steel locking handles will not rust and have wide openings for easy access
- No reduction in basket storage space

Low profile design improves truck rear window visibility by almost 50% versus standard height boxes



ATV Storage Boxes

CHALLENGER™ SPECIALITY SERIES

- Gas-mounted shock for easy accessibility and noise reduction while on the go
- Weather stripping provides additional protection from the elements
- Rugged diamond plate aluminum construction is rust resistant and more durable than plastic or cloth
- Attractive black powder coat finish resists cracking and fading, while minimizing reflections
- Black stainless steel latches with double post hooks for extra security
- Drain and ventilation holes for air circulation and easy cleaning
- Mounting kit included for easy, secure attachment



ATV Front Storage Box



ATV Rear Storage Box



CHALLENGER™ SPECIALTY SERIES

Quick and Easy Access



CHALLENGER™ TOPSIDE

Keeps bed free for cargo while creating convenient storage on top of truck bed rails. Great for the contractor or tradesman who needs to have quick and easy access to tools, cable, cleaning supplies and other items

- Heavy duty diamond plate aluminum construction with full welded seams
- Convenient drop down doors are supported with chains to prevent doors from hitting truck body
- Mounts securely to bed with stainless steel fasteners
- 3 sizes available (72", 90" and 96"). 72" model can be used with toolbox on trucks with 8' beds



CHALLENGER™ TRAILER UTILITY BOXES

Mount these versatile storage boxes on the tongue of a boat, utility or small watercraft trailer to provide lockable storage space for your valuables.

- Heavy duty diamond plate aluminum construction
- Hemmed lid with adjustable lid striker and weatherproof seal
- Stainless steel, lockable paddle handle offers increased security
- Gas strut lifts lid for easy access to box contents
- Available in 2 sizes
- Available in Black or Brite finish



TOTE BOXES

- Provides portable storage for hand tools and small parts, for home, work or vehicle.
- Boxes have lockable hasps, carrying handle, and straight or dome style lid
- 3 sizes (16", 24" and 30") in Brite Finish



CHALLENGER™ SPECIALTY SERIES

Quick and Easy Access

CHALLENGER™ SIDEMOUNT

Can be used as stand alone storage box or in conjunction with crossover box when maximum storage space is needed.

- Lockable, quick-release stainless handles
- Long, single lid design for storage of long items
- 3 sizes (48", 60" and 72") fits full size trucks
- Includes sliding tool tray and all mounting hardware
- Available in Black or Brite finish



CHALLENGER™ CHESTS

Convenient, lockable storage can be used in the bed of your truck, on a cargo carrier behind truck or RV, as a dock box, or as a heavy duty storage system in your garage or workshop.

- Twin commercial gas struts lift lid automatically for easy one handed use
- Lockable, quick-release stainless handles
- Long single lid design is ideal for storage of sporting goods, camping equipment, or bulky tools
- Available in 6 different sizes for full and downsize pickups



CHALLENGER™ UNDERBED BOXES

Underbed boxes mount under the truck bed or trailer on commercial vehicles, keeping the bed free for cargo.

- Heavy duty diamond plate aluminum construction with fully welded seams
- Flush mount access door with foam seal provides weather resistant protection and a finished look
- Stainless steel T-Handle latches for security and easy of opening





Thick Diamond Plate Body

ULTIMA™ SERIES



Single Lid Crossover



Gulf Wing Crossover



Black Finish



Brite Finish

- Constructed of thick diamond plate aluminum
- 3-piece box design
- Wider Lid opening
- Reinforced dome style lid with high quality foam weather stripping
- Full length piano style hinge and adjustable lid strikers
- Twin, 45# struts provide smooth, automatic lid lifting — even in cold weather
- Quick release, lockable stainless paddle handles with foam gasket behind to prevent moisture from entering box
- Deep molded tool tray provides storage for small items and sits above the ledge, allowing for maximum storage inside the box
- Built-in trays and tool holder



Durable Storage Boxes for the Value-Conscious

CONTENDER™ SERIES

- Thick diamond plate aluminum with 3 piece box construction and fully welded seams
- Reinforced dome style lid with weather proof seal, piano hinge, and fully adjustable strikers
- Commercial grade gas struts lifts lid automatically
- Quick release, weather-proof locking handles
- All mounting hardware included, some drilling required

TOOL BOX ACCESSORIES

Sold Separately



- Mounts toolbox securely into truck bed
- Works with most over-the-rail truck toolboxes*
- Heavy duty clamps, stronger than standard screws or j-hooks
- No drill installation - will not void vehicles' paint warranty

* Requires a minimum of 5/8" clearance between toolbox and inside of truck rail. Will not work with new composite truck beds.



SPORTTRAILS™

Curved Aluminum Side Rails



- Aluminum construction with rounded top edge adds style to any pickup
- Sleek design extends less than two inches above the height of the bed
- Foam mounting strips protect your vehicle's paint
- Tie-down anchor points keep cargo secure
- Available in anodized aluminum finish

GATEKEEPER™

Tailgate Protector



- Universal, cut-to-length black rubber protector
- Protects top of tailgate from nicks and scratches
- Easy, no-drill installation with strong automotive grade tape

TAILMATE™

Rear Valance



- Recessed license plate holder
- Custom designed for a perfect fit
- Mounting hardware is concealed for a smooth look
- Easy-to-paint white gelcoat finish
- Solid fiberglass construction



Diamond Plate or Buffed Extruded Aluminum

TAILGATE CAPS

- Tailgate and front rail caps install fast and easy with stainless steel fasteners for long lasting protection.
- Available in black for select applications



Full Protector

FULL TAILGATE PROTECTORS

- Heavy gauge, highly polished diamond plate full tailgate (shown) and full front protectors install fast and easy
- Available in black for select applications



Diamond or Black

SIDE RAIL CAPS

- Constructed of heavy-gauge, highly polished diamond plate aluminum
- Available in black for select applications
- Available in wrap and no-wrap designs, with or without stake pocket holes

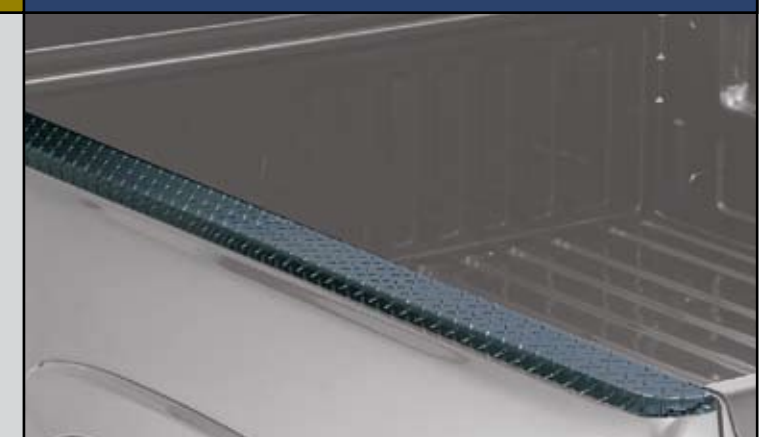

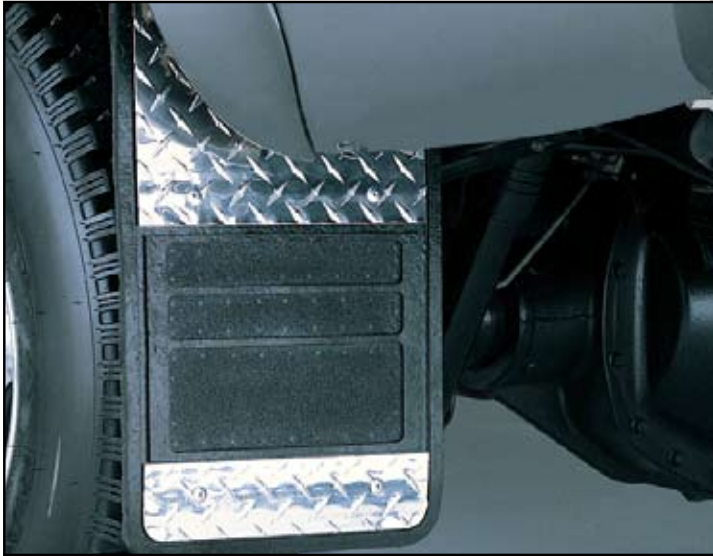

Lund Mud Flaps are designed to protect your vehicle from whatever the road throws at it

Custom designed for fast and easy installation, Lund Mud Flaps can extend the life of your vehicle's body and look great doing it. Both universal and custom models are available so, no matter what you drive, you can protect your vehicle and get the look.

CUSTOM MUD FLAPS

Durable Rubber/Aluminum Construction



Single Wheel - 930 Series

- 12" x 18" single-wheel mud flaps.
- Heavy duty molded rubber with diamond plate or polished stainless steel plates and pre-drilled holes
- Fits GM, Ford, Dodge, and Toyota full size trucks
- Includes custom installation brackets



Dually Wheel - 935 Series

- 18" x 24" dually mud flaps
- Heavy duty molded rubber with diamond plate or polished stainless steel plates and pre-drilled holes
- Fits GM, Ford and Dodge full size trucks
- Includes custom installation brackets

UNIVERSAL MUD FLAPS

Stylish Protection from Road Debris



- Universal design available in multiple sizes to fit most pickups and SUVs
- Diamond brite, extruded brite, or extruded black finish options
- "Moon" or "square" cut designs
- Mounting hardware included for quick and easy installation



Limited Lifetime Warranty

What Is Covered: All defects in materials or workmanship except paint and painting on all Lund International, Inc.'s Lund International™ Lund®, Nifty and Deflecta-Shield® Accessories branded products properly installed per provided instructions except those listed below under the One Year Warranty, Two Year Warranty or Three Year Warranty. This warranty does not apply to any product from Lund International's direct or indirect subsidiaries.

For How Long: This warranty, and any implied warranties including merchantability and fitness for a particular purpose, last as long as the original retail purchaser owns the vehicle on which the product is installed. The warranty expires if the product is removed from the original vehicle or if the original vehicle is transferred to another owner. The warranty is not transferable from the original purchaser.

Limited One Year Warranty

What Is Covered: All defects in materials or workmanship on all Pro-Line® branded replacement carpet -- Challenger™, Ultima™ and Contender™ branded storage boxes -- All Cargo Management products except the Folding Aluminum Ramp, Folding Aluminum Arched Ramp, Bi-Fold Ramps and Tri-Fold Ramps properly installed per provided instructions.

For How Long: This warranty, and any implied warranties including merchantability and fitness for a particular purpose, lasts one year from the date of purchase. The warranty expires if the product is removed from the original vehicle or if the original vehicle is transferred to another owner. The warranty is not transferable from the original purchaser.

Limited Two Year Warranty

What Is Covered: All defects in materials or workmanship except paint, painting or powder coating on Seal-Tite™ branded storage boxes properly installed per provided instructions.

For How Long: This warranty, and any implied warranties including merchantability and fitness for a particular purpose, lasts two years from the date of purchase. The warranty expires if the product is removed from the original vehicle or if the original vehicle is transferred to another owner. The warranty is not transferable from the original purchaser.

Limited Three Year Warranty

What Is Covered: All defects in materials or workmanship except paint and painting on the Stainless Interceptor™, Folding Aluminum Ramp, Folding Aluminum Arched Ramp, Bi-Fold Ramps and Tri-Fold Ramps properly installed per provided instructions.

For How Long: This warranty, and any implied warranties including merchantability and fitness for a particular purpose, lasts three years from the date of purchase. The warranty expires if the product is removed from the original vehicle or if the original vehicle is transferred to another owner. The warranty is not transferable from the original purchaser.

The following Paragraphs Apply to all Lund International, Inc. Warrantees:

What Lund International Will Do: During the applicable warranty period listed above, Lund International will, at its option, either repair or replace any defective product at no charge. You must pay any labor charges associated with removing or reinstalling the product. If a specific product has been discontinued, Lund International may, at its option, replace your product with a current product of comparable function and value.

What These Warranties Will Not Cover: These warranties do not cover any damage, defect, or malfunction caused by misuse, abuse, accident, improper installation, modification, improper or inadequate maintenance, or on-road and off-road hazards. Incidental and consequential damages are not recoverable under this warranty. Some states or provinces do not allow the exclusion or limitation of incidental or consequential damages, so this exclusion or limitation may not apply to you.

How To Get Service: A defective product may, during the warranty period listed above, be returned to the place of purchase. Alternatively, you may contact Lund International Customer Relations directly at 1-800-328-5863 for information on how to obtain service. Proof of purchase must accompany all warranty returns. Returns made to Lund International will not be accepted without prior authorization from Lund International.

How Does State Law Apply? This warranty gives you specific legal rights, and you may have other rights which vary from state to state or province to province.

This warranty statement supersedes all previous warranty statements in Lund® Nifty® and/or Deflecta-Shield® Accessories catalogs or other marketing materials.